

# TANDEM – runner system



## ► Basic elements

## ►► Full extension – drawer/inner drawer – 560H

### Product

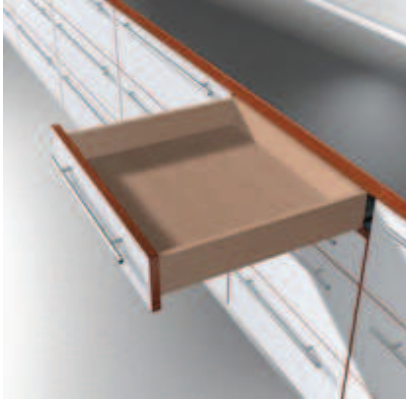

### Description

- Concealed TANDEM full extension with integrated **BLUMOTION** for silent and effortless closing action
- Dyn. load bearing 30 kg
- TANDEM inside – for unparallelled running action for the lifetime of the furniture
- Tool-free height adjustment in locking device
- Tool-free integrated front tilt adjustment
- Built-in width and depth tolerance compensation
- BLUMATIC self closing feature

### Space requirement

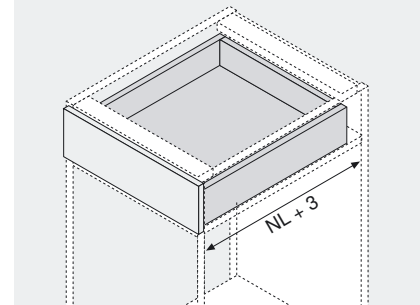

NL Nominal length

### Ordering information

1	Runners left/right		
Nominal length NL	TANDEM plus BLUMOTION	TANDEM plus *	* Suitable for TIP-ON
250 mm	560H2500B	560H2500C	
270 mm	560H2700B	560H2700C	
300 mm	560H3000B	560H3000C	
320 mm	560H3200B	560H3200C	
350 mm	560H3500B	560H3500C	
380 mm	560H3800B	560H3800C	
400 mm	560H4000B	560H4000C	
420 mm	560H4200B	560H4200C	
450 mm	560H4500B	560H4500C	
480 mm	560H4800B	560H4800C	
500 mm	560H5000B	560H5000C	
520 mm	560H5200B	560H5200C	
550 mm	560H5500B	560H5500C	
600 mm	560H6000B	560H6000C	

3	Locking device left/right		
	orange	left hand	T51.1700.04
	orange	right hand	T51.1700.04

4	Front adjustment bracket (optional)	
	natural	295.1000
	Nylon	

5	POSISTOP (optional)	
	Nylon	RAL 7037 dust grey
	Depth stop for inner drawers without TIP-ON	
		298.5500

6	TIP-ON left/right (optional)	
	For handle-less fronts	
	Only suitable for TANDEM plus	
		T55.7150

### Drawer

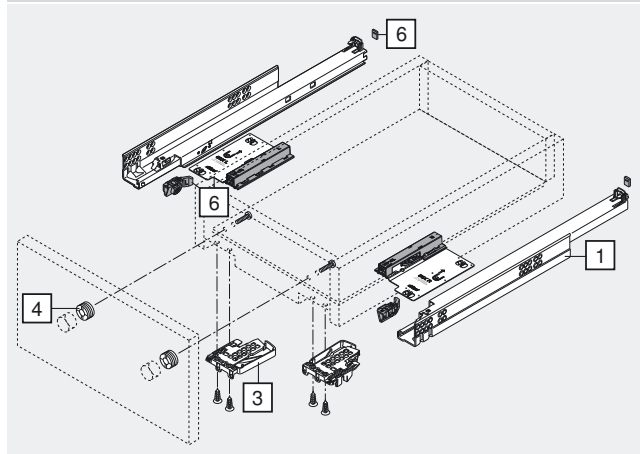

### Inner drawer

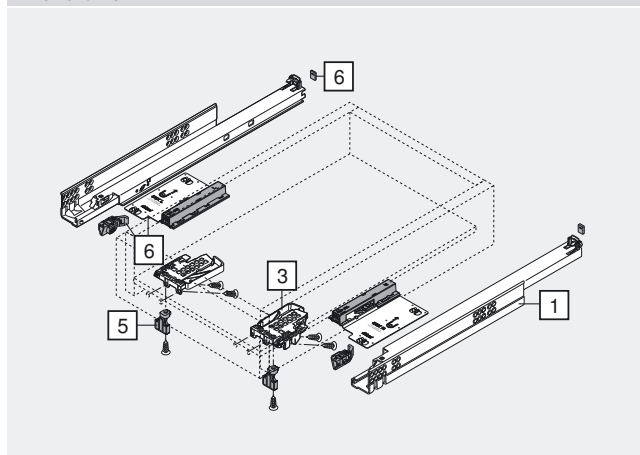

TANDEM

# TANDEM – runner system

## ► Basic elements

## ►► Full extension – drawer/inner drawer – 560H

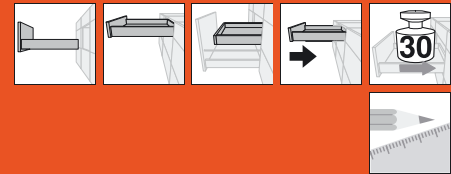

### Planning

Space requirements in cabinet	Drawer/inner drawer	Drawer	Inner drawer
* + 1 mm with TIP-ON T55.7150	SKW Internal drawer width LW Inner cabinet width	SKL Drawer length NL Nominal Length	ISKL Inner drawer length SKL Drawer length NL Nominal length * + 3 mm with TIP-ON

### Cabinet profile screw positions

Nominal length NL (mm)

250, 270	
300, 320	
350, 380	
400, 420	
450, 480	
500, 520, 550	
600	

Min. internal cabinet depth = nominal length NL + 3 mm

Cabinet profile fixing positions

452

### Drawer assembly

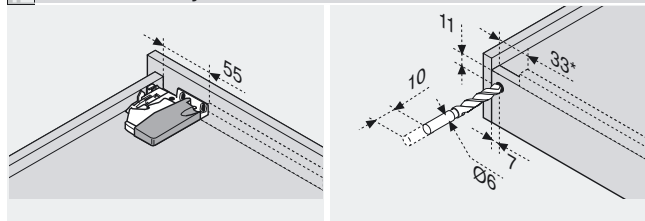

Use drilling template T65.1000

\* 85 mm with TIP-ON T55.X150  
Use drilling template T65.1000

### Page instructions

Overview – TANDEM plus BLUMOTION – basic elements	400	ORGA-LINE-application – odds & ends	516	Assembly devices	556
Overview – SERVO-DRIVE for TANDEM	458	ORGA-LINE-application – kitchen utensils/knives/small electric appliances	516	More technical details	658
Overview – TIP-ON for TANDEM	508	ORGA-LINE-application – cooking utensils	517		
Overview – ORGA-LINE for TANDEM	512	ORGA-LINE-sets/accessories	518		
ORGA-LINE-application – cutlery	516	Accessories	450		
		Assembly and adjustment	454		